





## LEADERS IN LARGE FORMAT PRINTING, BRANDING AND ACTIVATION.

Based in Sandton and formed in 1955, Swift Displays is one of the longest standing printing companies in South Africa.

Through innovation, quality and value for money, the company has established itself as a leader predominantly in the large format printing market.

A complete turnkey solution offered by Swift Displays. From exciting initial concepts in conjunction with the client's vision including full-service design, DTP and pre-press. In addition, 360-720 dpi roll to roll printing, flatbed and screen printing, installation, lighting, project management, digital signage as well as web and litho printing.

Our IdeaLab will suggest and compile structurally sound and professionally designed renders using award-winning industrial design software (ESKO). This allows the client to visually understand how their project will look in reality. Every technical aspect of the final product is tested digitally prior to production of a sample.

We are experts in graphic arts with a DTP studio on site. We analyse and check all artwork, size and colour before sending off to the output units for optimum efficiency and manufacture. CGS Colour Management Software ensures all jobs will have colour consistency regardless of which machine it is printed on.

Swift Displays offers you versatility and capacity that is supported by industrial equipment and machinery available for multiple media and advertising formats. We keep abreast of international trends and market needs and take pride in leading the industry within South Africa. Equipment, software, machinery, technology, environmental impact and quality stand out amongst other players in this field. We simply do not cut corners and offer our clients the very best value for money.

Swift Displays owns water based environmentally friendly high high-quality Latex machines, super grand format UV machines that are able to print at 300 m<sup>2</sup> per hour equating to 300 000 m<sup>2</sup> per month. We are the first company in Africa to purchase the FB7600 Industrial Press from HP.

Textile and fabric soft signage products are expertly printed using strikingly bright UV inks, or for shorter campaigns, water based latex inks. Anything from a gazebo to a fabric frame, our textile graphics are amazing.

All our finishing services are done in-house using Zund Automatic digital die cutting machines, 3 m guillotines, UV coating, PVC welding, sewing, eyeletting and heat bending, we do it all.

Our expert project management, account executives, outdoor media specialists and client service teams take care of every project from concept to delivery based on your detailed brief and project specifications. These team members will professionally guide you through the various processes of production; managing overnight tight deadlines and ensuring accurate on-time delivery and post-campaign reporting. This includes managing multi-national retail store roll outs, logistically moving and lighting hundreds of billboard campaigns as well as wrapping fleets of buses and taxis. Our installation teams, lighting and height access technicians around the country are trained and skilled to add the final touches to any campaign.



As a subsidiary of the Formeset Group of companies, Swift Displays has access to additional printing formats. Using litho and digital printing covers the demand of magazines, brochures and flyers, with an efficient turnaround.

Digital signage in reception areas, stores and retail spaces using LCD screens, video walls or microtiles reinvents the advertising experience to your consumers. Giant high-resolution screens, short term personalised and mobile screens for all types of campaigns, is implemented and managed by our teams for the duration of the activation.

The Swift Displays team is proud to have worked with world class brands subscribing to unparalleled service, quality and delivery. The numerous years of experience, commitment and energy ensure that Swift Displays is selected as your partner to build your brand.



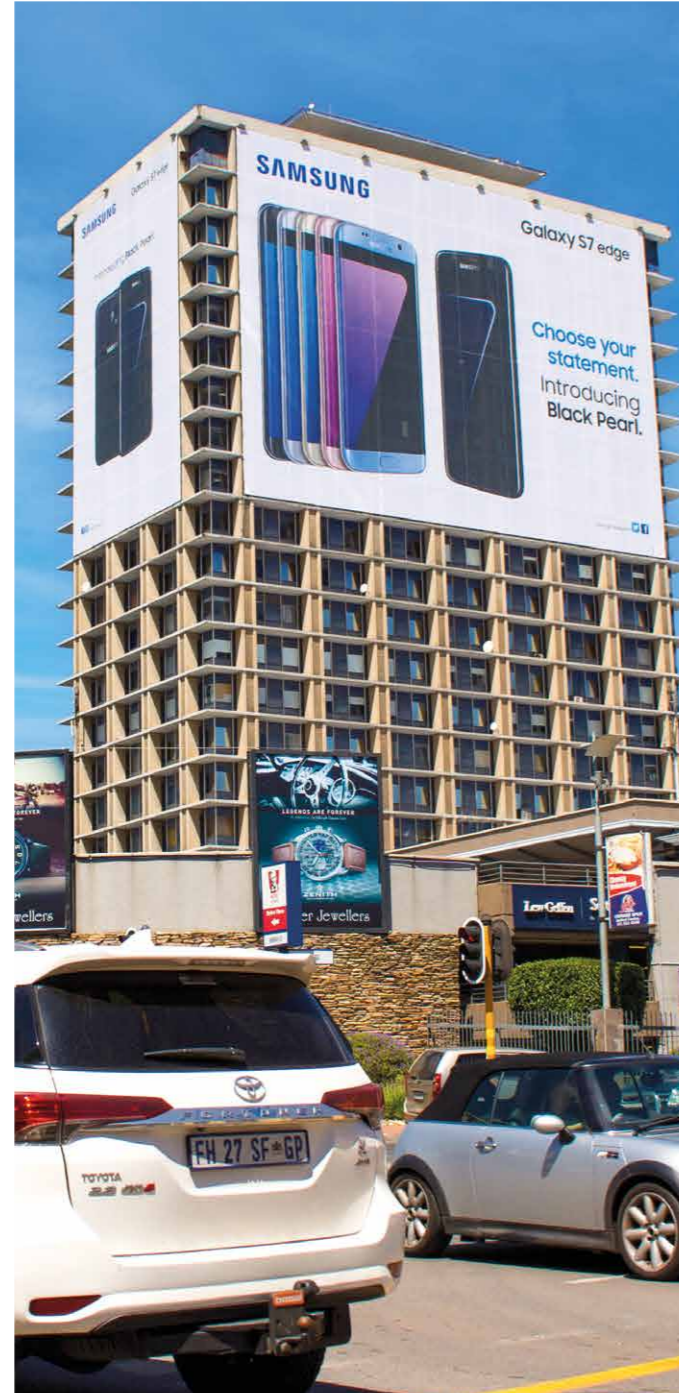





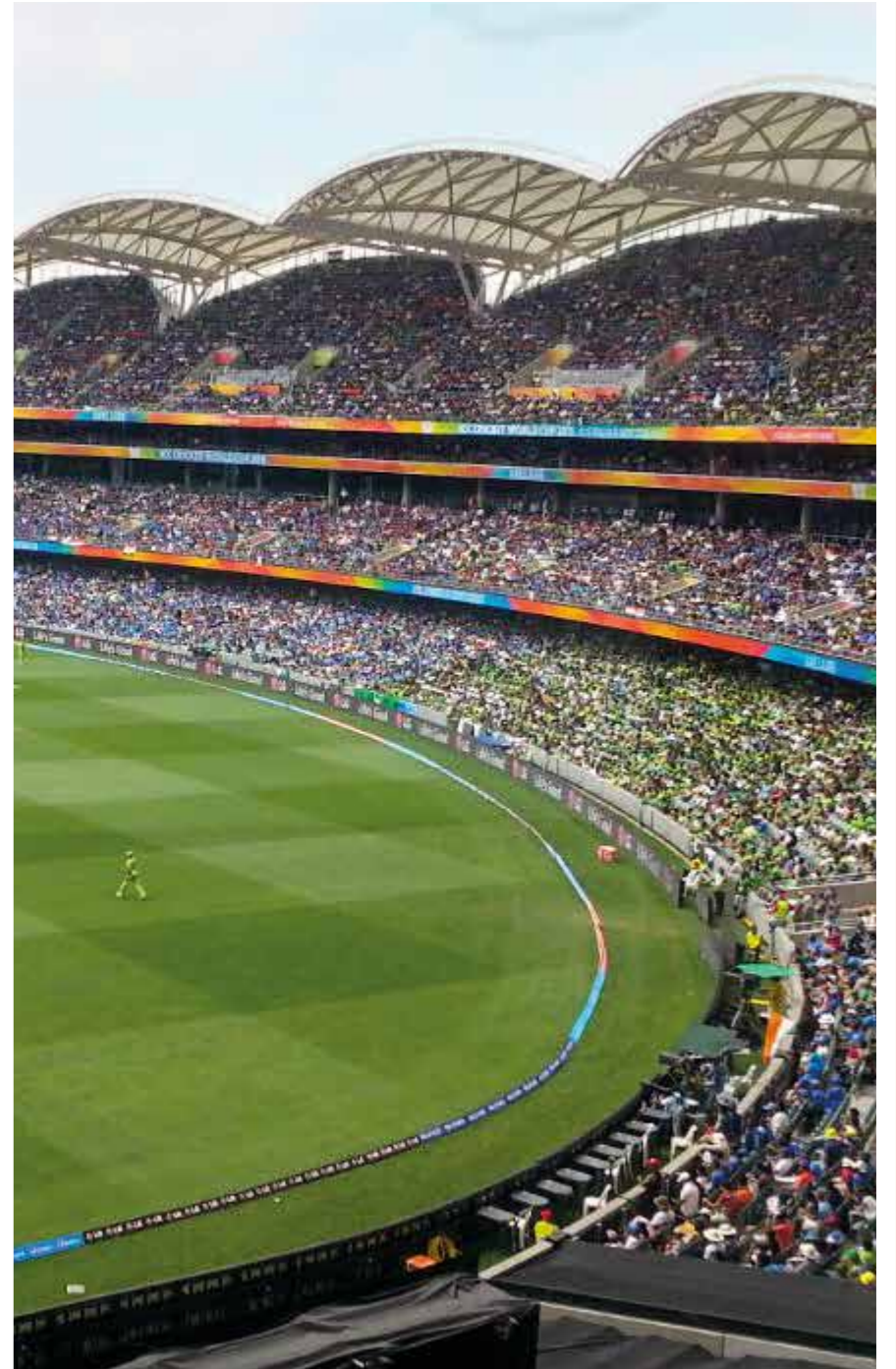



# IDEA LAB

Floor standing units | Point of Sale designs | Packaging solutions | Campaign integration | 3D Proofing & layout



# HIGH QUALITY EQUIPMENT, HIGH QUALITY PRODUCTS.



## High Quality

- 1 x 5m VUTEK UV Inks
- 1 x 5m HP Scitex UV Inks
- 1 x 3.2m HP Scitex Solvent
- 1 x 3.2m HP Scitex UV Inks
- 600 000sqm capacity

## Large Format

- 3 x HP LX820
- Water based inks
- Environmentally friendly
- Extremely high quality
- 24/7 operation



## Flatbed

- FB7600 Flatbed Digital Printer 3200 x 1600mm
- 4 x ATMA Screen presses
- Direct to any surface
- Outdoor UV durable inks
- Chromadek, Xanita
- Foam board, Corex decals, fleet and wall paper



## EFI VUTEK FabricUV

- EFI VUTEK FabriVU 3200mm
- Direct to textile or indirect via transfer process
- Ultra-high resolution up to 2,400 dpi and four level grayscale printing with 4pL to 18pL drop sizes
- Banners, flags, furnishings, soft signage, wall coverings

**VUTEK™**  
HS100

**efi**

**hp**

**ZÜND**  
swiss cutting systems

# HIGH QUALITY EQUIPMENT, HIGH QUALITY PRODUCTS.

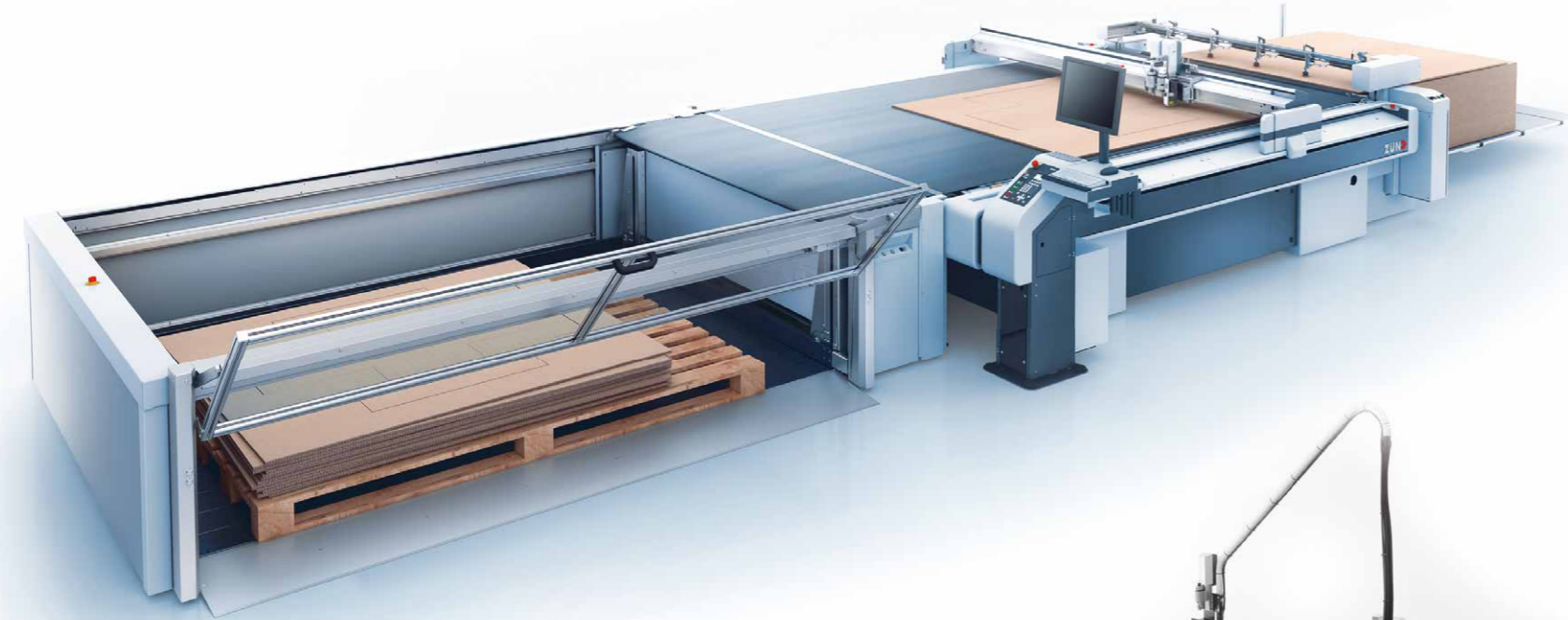

## Zund Digital Cutter

- Quality and precision cutting
- Qualified for industrial use and multi-shift, 24/7 operation
- Intelligent control technology, robust system components, and sophisticated tooling

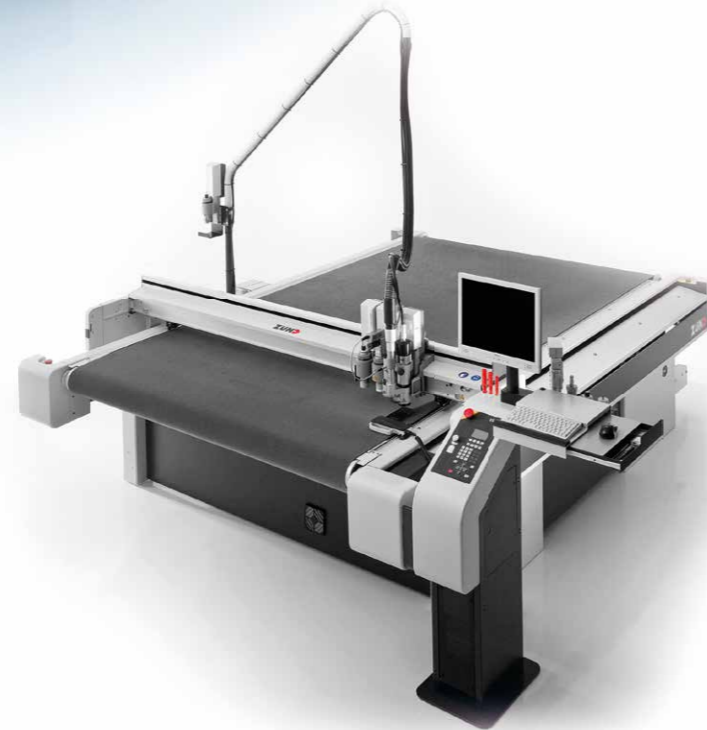

## Vutek HS100 Pro

- Handles flexible or rigid substrates up to 3.2m and up to 5.08cm thick
- Expanded gamut CMYK pigments for world class Pantone matching
- Standard six colors (CMYK, Ic, Im) plus two white channels
- 3.2 meter hybrid digital UV press handles up to 100 boards per hour; up to 70 boards per hour in Point-Of-Purchase mode (600 dpi binary print mode)

## HP Scitex XP5300

- Ability to print directly on inexpensive media such as polyethylene, PVC banner, synthetic paper and textiles up to 5m wide
- Simultaneous printing on three different rolls, each up to 1.6m wide
- 4-color printing system with versatile, fast-drying UV inks that provide application versatility and superior image quality



**VUTEK™**  
HS100

**efi**

**hp**

**ZÜND**  
swiss cutting systems

# WHY TRUST YOUR BRAND WITH ANYONE ELSE

- Billboards
- Building wraps
- Street graphics
- Wallpaper
- Taxi Fleets
- Vehicle branding
- Vinyl cutting
- Applications
- Activations
- Bus shelters
- Digital die cutting
- Retail stands
- POS designs
- Floor standing units
- Point of sale designs
- Packaging solutions
- Campaign integration
- 3D Proofing & layout
- Video walls
- Interactive retail windows
- Customised portable screens
- Menu boards
- Lightboxes
- Window graphics



7 Commerce Crescent West, Eastgate Ext 13, Sandton  
P.O. Box 76249, Wendywood, 2144  
Tel: +27 11 555 5700 | Fax: +27 11 555 5721

[www.swiftdisplays.com](http://www.swiftdisplays.com)  
BEE Level 2 Contributor